

Quick NEO

¥ 290,000



Frame	ALL-NEW Quick NEO, SmartForm C1 Alloy, SAVE, Ai, flat mount brake, 142x12 thru-axle
Fork	ALL-NEW Quick NEO Disc, BallisTec Carbon, 1-1/8" to 1.5" tapered steerer, 55mm offset, flat mount, 12x100 thru axle
Drive Unit	Bosch Active Line Plus 250W
Battery	Bosch PowerTube 500Wh
Display	Bosch Purion
Charger	Bosch 2A
Rims	Cannondale C2, 32h, Double wall
Hubs	(F) Formula RX-512 12x100 / (R) Formula DC-142 12x142
Spokes	DT Swiss Champion
Tires	Schwalbe G-One Allround Performance, 700 x 35c, RaceGuard
Pedals	Cannondale Urban Pedal
Crank	Bosch Gen3 w/ custom Ai offset spider, 38T
Chain	Shimano HG93, 9-speed
Rear Cogs	Shimano HG200, 11-36, 9-speed

Rear Derailleur	Shimano Altus
Shifters	Shimano Altus, 1x9
Handlebar	Cannondale 3 Flat, 6061 double-buttet Alloy, 8° sweep, 720mm
Grips	Cannondale Ergo Fitness Dual Density, Lock-on
Stem	Cannondale 3 alloy, 31.8mm clamp
Headset	Integrated, 1-1/8 to 1.5", sealed angular contact bearings
Brakes	Shimano MT200 hydro disc, 160/160mm RT26 rotors
Brake Levers	Shimano MT200 hydro disc
Saddle	Fabric Scoop Radius Sport, steel rails
Seatpost	Cannondale 3, 6061 Alloy, 25.4x350MM S/M, 400MM LG/XL
Connectivity	Wheel Sensor
Sizes	S, M, L
Color	Emerald (EMR)
Extra	Cannondale Kickstand, prewired front and rear light cable, Cannondale Wheel Sensor

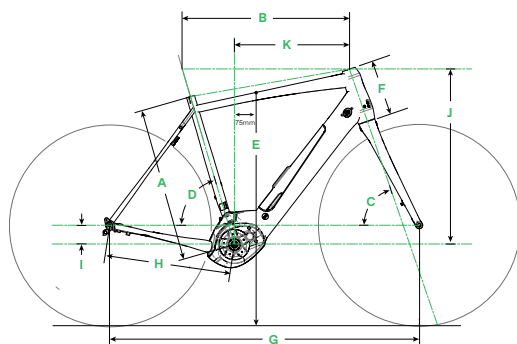

	S	M	L
A Seat Tube Length (cm)	44.5	49.0	53.5
B Top Tube Horizontal (cm)	53.5	55.2	57.6
C Head Tube Angle	71.0°	*	*
D Seat Tube Angle	74.0°	74.0°	73.5°
E Standover (cm)	73.0	77.0	81.0
F Head Tube Length (cm)	12.6	15.7	19.1
G Wheelbase (cm)	103.4	105.3	107.3
H Chain Stay Length (cm)	43.8	*	*
I Bottom Bracket Drop (cm)	6.7	*	*
J Stack (cm)	54.5	57.5	60.7
K Reach (cm)	37.9	38.7	39.6

cannondale